



HIGHNESSTM

HM101WX101I-RT

**10.1" Color TFT-LCD with
Resistive Touch Screen**

THIS DOCUMENT CONTAINS PROPRIETARY INFORMATION WHICH IS SOLELY OWENED BY 'HIGHNESS MICROELECTRONICS
PVT. LTD.'" ANY UNAUTHORISED COPY OR PRINTING OR PUBLISHING OF INFORMATION IN
THIS DOCUMENT IN PART OR IN COMPLETE IS RESTRICTED.

HIGHNESS MICROELECTRONICS PVT. LTD

URL: www.highnessmicro.com, Email: sales@highnessmicro.com

1. GENERAL DESCRIPTION

1.1 OVERVIEW

HM101WX101I-RT is a 10.1" TFT Liquid Crystal Display with Resistive Touch Screen, LED Backlight units and 40 pins LVDS interface. This module supports 1280 x 800 WXGA mode and can display 16.2M/ 262k colors. The LED driving device for Backlight is built in PCBA.

1.2 FEATURES

- WXGA (1280 x 800 pixels) resolution
- DE (Data Enable) only mode
- LVDS Interface with 1pixel/clock
- Wide operating temperature.
- RoHS compliance

1.3 APPLICATION

- TFT LCD Monitor
- Factory Application
- Amusement

1.4 GENERAL SPECIFICATIONS

Item	Specification	Unit	Note
Active Area	216.96 (H) x 135.60 (V) (10.1" diagonal)	mm	(1)
Bezel Opening Area	218.96 (H) x 137.6 (V)	mm	
Driver Element	a-Si TFT active matrix	-	-
Pixel Number	1280 x R.G.B x 800	pixel	-
Pixel Pitch	0.1695 (H) x 0.1695 (V)	mm	-
Pixel Arrangement	RGB vertical Stripe	-	-
Display Colors	16,194,277 / 262,144	color	-
Display Mode	Normally Black	-	-
Surface Treatment	Hard Coating (3H), Anti-Glare	-	-
Module Power Consumption	6.18	W	Typical
Touch Screen Type	Resistive Touch	-	-
Touch Screen Interface	USB	-	-

1.5 MECHANICAL SPECIFICATIONS

Item		Min.	Typ.	Max.	Unit	Note
Active Area	Horizontal	-	216.96	-	mm	
	Vertical	-	135.6	-	mm	

Note (1) Please refer to the attached drawings for more information of front and back outline dimensions.

Note (2) The depth is without connector.

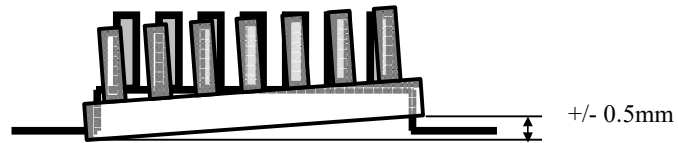

2. ABSOLUTE MAXIMUM RATINGS

2.1 ABSOLUTE RATINGS OF ENVIRONMENT

Item	Symbol	Value		Unit	Note
		Min.	Max.		
Operating Ambient Temperature	T _{OP}	-20	+65	°C	
Storage Temperature	T _{ST}	-25	+70	°C	

Note (1) Temperature and relative humidity range is shown in the figure below.

- (2) 90 %RH Max. (Ta < 40°C).
- (3) Wet-bulb temperature should be 39°C Max.
- (4) No condensation.

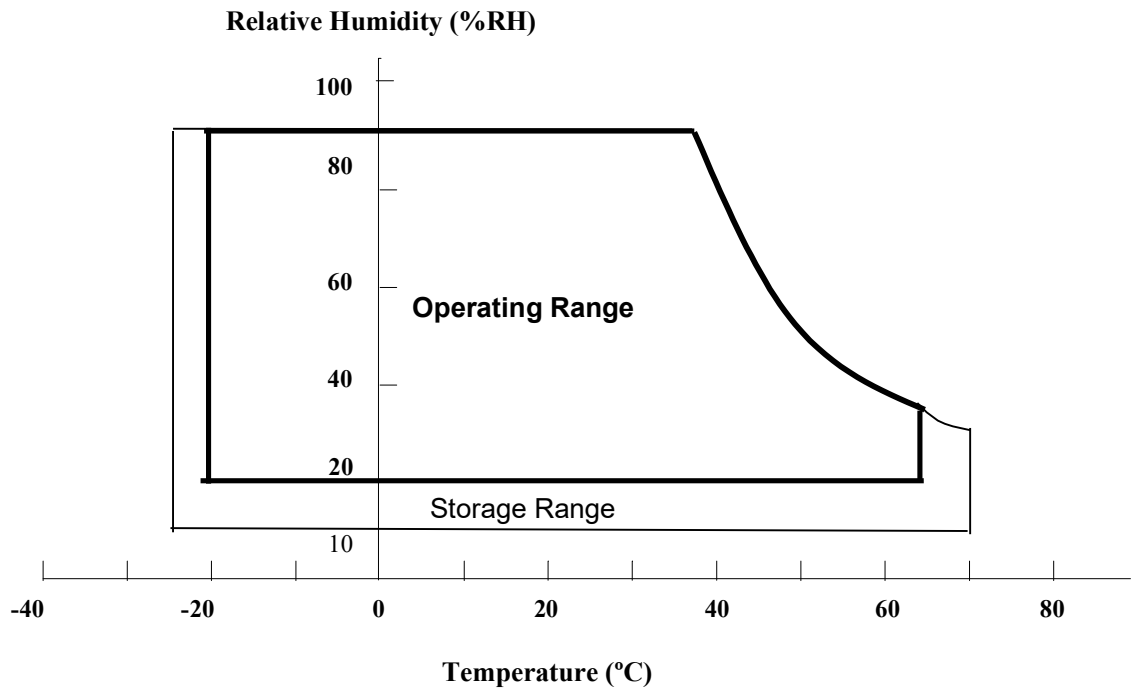

2.2 ELECTRICAL ABSOLUTE RATINGS

2.2.1 TFT LCD MODULE

Item	Symbol	Value		Unit	Note
		Min.	Max.		
Power Supply Voltage	VCC	-0.3	4	V	(1)

2.2.2 BACKLIGHT UNIT

Item	Symbol	Value		Unit	Note
		Min.	Max.		
Converter Voltage	V _i	-0.3	18	V	(1), (2)
Enable Voltage	EN	---	5.5	V	
Backlight Adjust	ADJ	---	5.5	V	

Note (1) Permanent damage to the device may occur if maximum values are exceeded. Function operation should be restricted to the conditions described under Normal Operating Conditions.

Note (2) Specified values are for lamp (Refer to 3.2 for further information).

3. ELECTRICAL CHARACTERISTICS

3.1 TFT LCD MODULE

Parameter	Symbol	Value			Unit	Note
		Min.	Typ.	Max.		
Power Supply Voltage	V_{CC}	3.0	3.3	3.6	V	-
Ripple Voltage	V_{RP}	-	-	100	mVp-p	
Rush Current	I_{RUSH}	-	-	1.5	A	(2)
Power Supply Current	White	-	265	320	mA	(3)a
	Black	-	210	260	mA	(3)b
LVDS differential input voltage	V_{id}	200	-	600	mV	
LVDS common input voltage	V_{ic}	1.0	1.2	1.4	V	
Differential Input Voltage for LVDS Receiver Threshold	"H" Level			100	mV	-
	"L" Level				mV	-
Terminating Resistor	R_T	-	100		Ohm	-

Note (1) The module should be always operated within above ranges.

Note (2) Measurement Conditions:

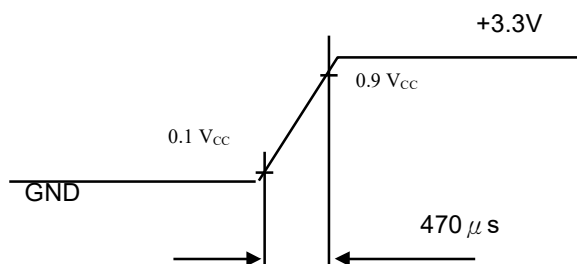
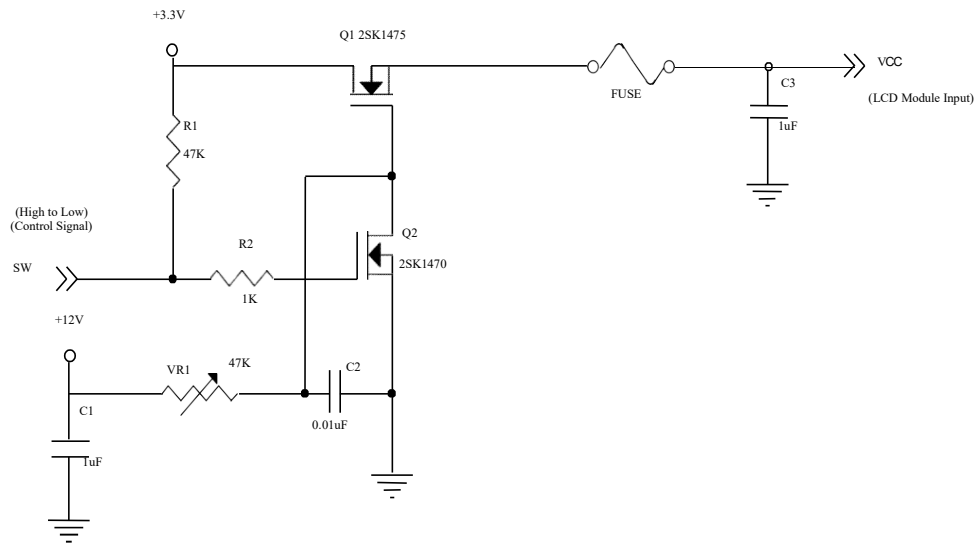

Note (3) The specified power supply current is under the conditions at $V_{DD} = 3.3V$, $T_a = 25 \pm 2 \text{ }^\circ\text{C}$, DC Current and $f_v = 60 \text{ Hz}$, whereas a power dissipation check pattern below is displayed.

a. White Pattern

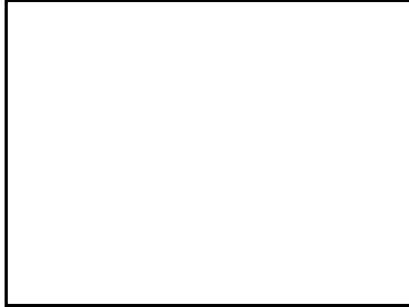

Active Area

b. Black Pattern

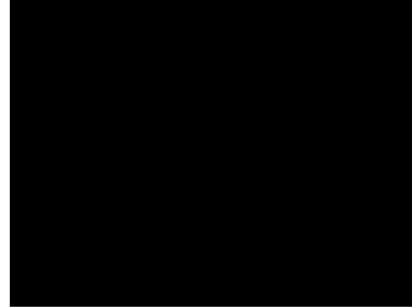

Active Area

3.2 BACKLIGHT UNIT

$T_a = 25 \pm 2 \text{ }^\circ\text{C}$

Parameter	Symbol	Value			Unit	Note
		Min.	Typ.	Max.		
Converter Power Supply Voltage	V_i	10.8	12.0	13.2	V	
Converter Power Supply Current	I_i	-	0.45	0.50	A	@ $V_i = 12V$ (Duty 100%)
Backlight Power Consumption	P_{BL}	-	5.3	5.8	W	@ $V_i = 12V$ (Duty 100%)
EN Control Level	Backlight on	2.5	3.3	5.0	V	
	Backlight off	0	---	0.8	V	
PWM Control Level	PWM High Level	2.5	3.3	5.0	V	
	PWM Low Level	0	-	0.15	V	
PWM Control Duty Ratio	-	1	-	100	%	@200Hz
PWM Control Frequency	f_{PWM}	190	200	20k	Hz	(2)
LED Life Time	L_L	50,000	-	-	Hrs	(3)

Note (1) LED current is measured by utilizing a high frequency current meter as shown below:

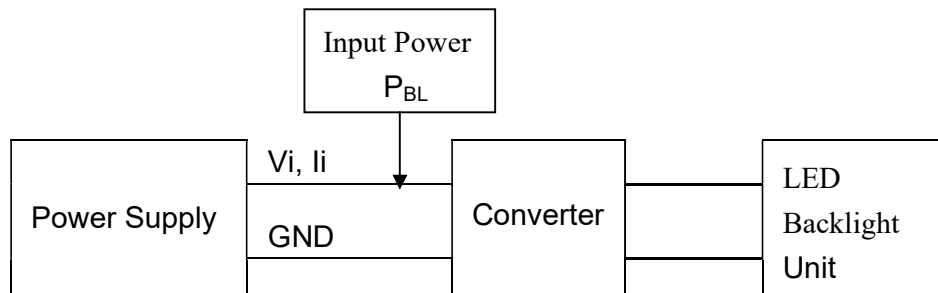

Note (2) At 200 Hz PWM control frequency, duty ratio range is restricted from 1% to 100%

Note (3) The lifetime of LED is defined as the time when it continues to operate under the conditions at $T_a = 25 \pm 2 \text{ }^\circ\text{C}$ and Duty 100% until the brightness becomes $\leq 50\%$ of its original value. Operating LED under high temperature environment will reduce life time and lead to color shift.

Power sequence and control signal timing are shown in the following figure

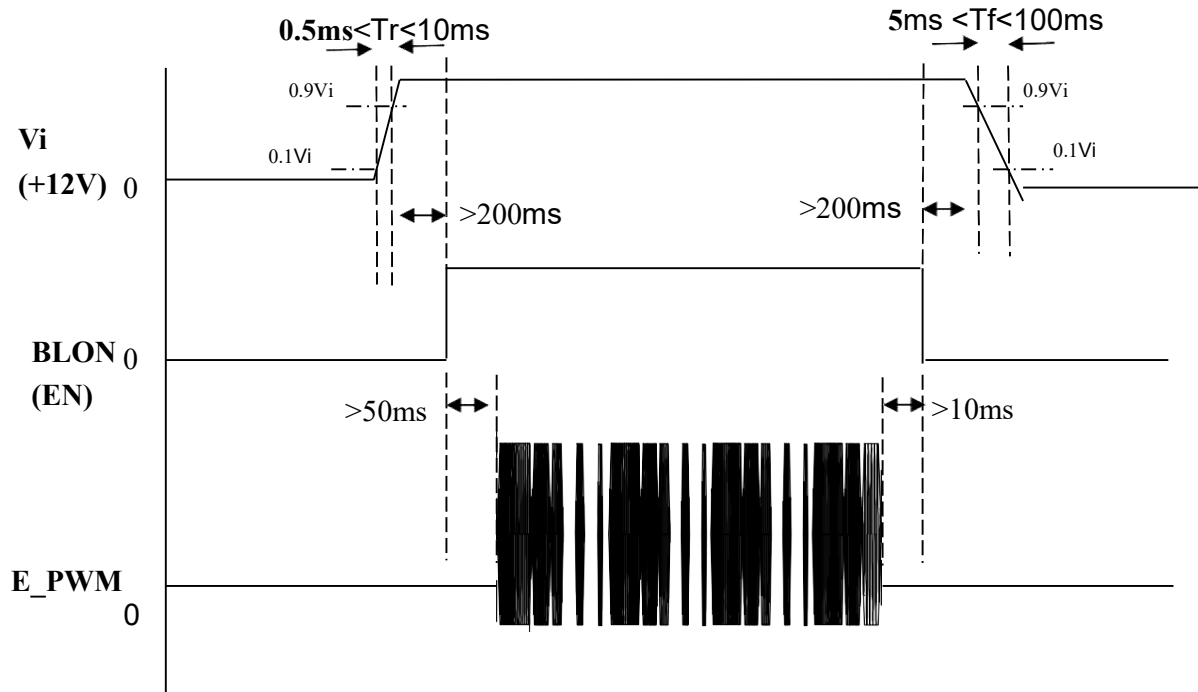

Note : While system is turned ON or OFF, the power sequences must follow as below descriptions

Turn ON sequence: $V_i(+12V) \rightarrow \text{BLON} \rightarrow \text{E_PWM}$ signal

Turn OFF sequence: E_PWM signal $\rightarrow \text{BLON} \rightarrow V_i(+12V)$

4. BLOCK DIAGRAM

4.1 TFT LCD MODULE

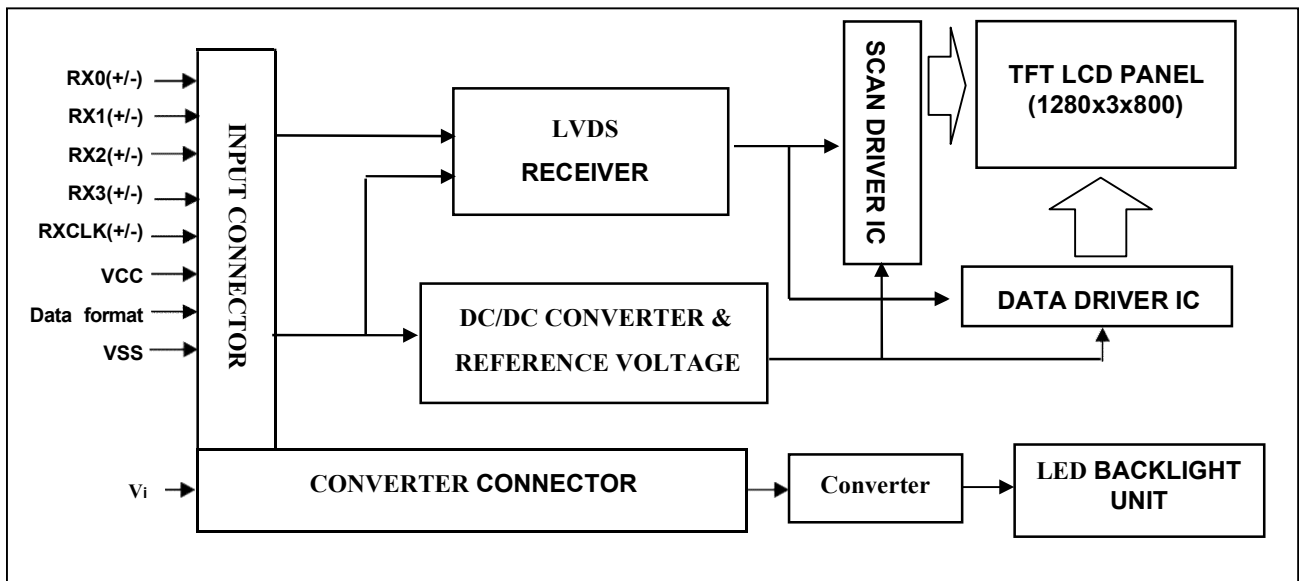

5. INPUT TERMINAL PIN ASSIGNMENT

5.1 TFT LCD MODULE

Pin No.	Symbol	Function	Polarity	Note
1	VCCS	Power Supply +3.3V(typical)		
2	VCCS	Power Supply +3.3V(typical)		
3	VCCS	Power Supply +3.3V(typical)		
4	Data format	L or NC : 8bit Input Mode H : 6bit Input Mode		Note (2),Note(3)
5	NC	No Connction (Reserve for INX test)		
6	NC	No Connction (Reserve for INX test)		
7	NC	No Connction (Reserve for INX test)		
8	Rxin0-	LVDS Differential Data Input	Negative	
9	Rxin0+	LVDS Differential Data Input	Positive	
10	VSS	Ground		
11	Rxin1-	LVDS Differential Data Input	Negative	
12	Rxin1+	LVDS Differential Data Input	Positive	
13	VSS	Ground		
14	Rxin2-	LVDS Differential Data Input	Negative	
15	Rxin2+	LVDS Differential Data Input	Positive	
16	VSS	Ground		
17	RxCLK-	LVDS Differential Clock Input	Negative	
18	RxCLK+	LVDS Differential Clock Input	Positive	
19	VSS	Ground		
20	Rxin3-	LVDS Differential Data Input	Negative	
21	Rxin3+	LVDS Differential Data Input	Positive	
22	VSS	Ground		
23	NC	No Connction (Reserve)		
24	NC	No Connction (Reserve)		
25	VSS	Ground		
26	VSS	Ground		
27	LED_PWM	PWM Control Signal od LED Converter		
28	LED_EN	Enable Control Signal od LED Converter		
29	LED_GND	LED Ground		
30	LED_GND	LED Ground		
31	LED_GND	LED Ground		
32	LED_GND	LED Ground		
33	LED_GND	LED Ground		
34	NC	No Connction (Reserve)		
35	NC	No Connction (Reserve)		
36	LED_VCCS	LED Power Supply		
37	LED_VCCS	LED Power Supply		
38	LED_VCCS	LED Power Supply		
39	LED_VCCS	LED Power Supply		
40	LED_VCCS	LED Power Supply		

Note (1) Connector Part No.: I-PEX 20455-040E-12 or Tyco_5-2069716-3.

Note (2) "Low" stands for 0V. "High" stands for 3.3V. "NC" stands for "No Connection".

Note (3) Interface optional pin has internal scheme as following diagram, Customer should keep the interface voltage level requirement which including panel board loading as below.

Data format Pin

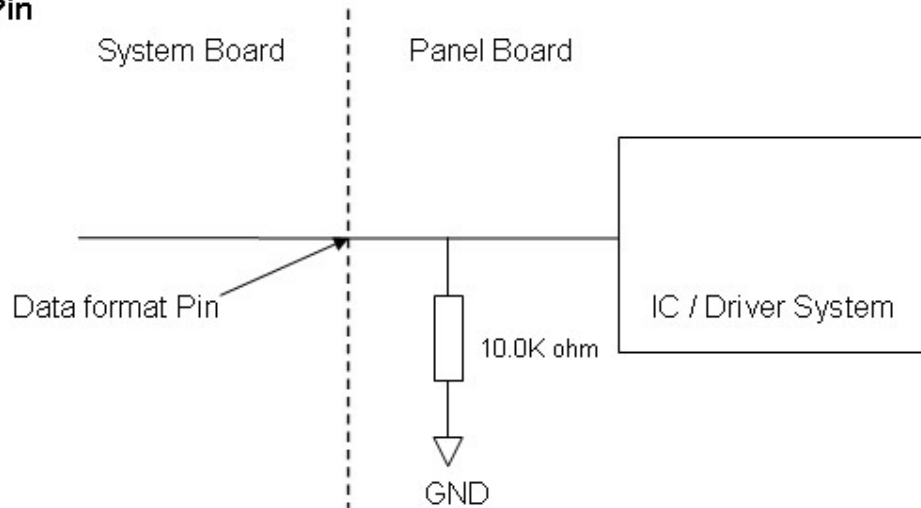

5.2 COLOR DATA INPUT ASSIGNMENT

The brightness of each primary color (red, green and blue) is based on the 8-bit gray scale data input for the color. The higher the binary input the brighter the color. The table below provides the assignment of color versus data input.

Color		Data Signal																							
		Red								Green								Blue							
		R7	R6	R5	R4	R3	R2	R1	R0	R7	R6	G5	G4	G3	G2	G1	G0	R7	R6	B5	B4	B3	B2	B1	B0
Basic Colors	Black	0	0	0	0	0	0	0	0	0	0	0	0	0	0	0	0	0	0	0	0	0	0	0	0
	Red	1	1	1	1	1	1	1	1	0	0	0	0	0	0	0	0	0	0	0	0	0	0	0	0
	Green	0	0	0	0	0	0	0	0	1	1	1	1	1	1	1	1	0	0	0	0	0	0	0	0
	Blue	0	0	0	0	0	0	0	0	0	0	0	0	0	0	0	0	1	1	1	1	1	1	1	1
	Cyan	0	0	0	0	0	0	0	0	1	1	1	1	1	1	1	1	1	1	1	1	1	1	1	1
	Magenta	1	1	1	1	1	1	1	1	0	0	0	0	0	0	0	0	1	1	1	1	1	1	1	1
	Yellow	1	1	1	1	1	1	1	1	1	1	1	1	1	1	1	1	0	0	0	0	0	0	0	0
	White	1	1	1	1	1	1	1	1	1	1	1	1	1	1	1	1	1	1	1	1	1	1	1	1
Gray Scale Of Red	Red(0) / Dark	0	0	0	0	0	0	0	0	0	0	0	0	0	0	0	0	0	0	0	0	0	0	0	
	Red(1)	0	0	0	0	0	0	0	1	0	0	0	0	0	0	0	0	0	0	0	0	0	0	0	
	Red(2)	0	0	0	0	0	0	1	0	0	0	0	0	0	0	0	0	0	0	0	0	0	0	0	
	⋮	⋮	⋮	⋮	⋮	⋮	⋮	⋮	⋮	⋮	⋮	⋮	⋮	⋮	⋮	⋮	⋮	⋮	⋮	⋮	⋮	⋮	⋮	⋮	
	⋮	⋮	⋮	⋮	⋮	⋮	⋮	⋮	⋮	⋮	⋮	⋮	⋮	⋮	⋮	⋮	⋮	⋮	⋮	⋮	⋮	⋮	⋮	⋮	
	⋮	⋮	⋮	⋮	⋮	⋮	⋮	⋮	⋮	⋮	⋮	⋮	⋮	⋮	⋮	⋮	⋮	⋮	⋮	⋮	⋮	⋮	⋮	⋮	
	Red(252)	1	1	1	1	1	1	0	1	0	0	0	0	0	0	0	0	0	0	0	0	0	0	0	
	Red(252)	1	1	1	1	1	1	1	0	0	0	0	0	0	0	0	0	0	0	0	0	0	0	0	
Red(252)	1	1	1	1	1	1	1	0	0	0	0	0	0	0	0	0	0	0	0	0	0	0	0		
Gray Scale Of Green	Green(0)/Dark	0	0	0	0	0	0	0	0	0	0	0	0	0	0	0	0	0	0	0	0	0	0	0	
	Green(1)	0	0	0	0	0	0	0	0	0	0	0	0	0	0	1	0	0	0	0	0	0	0	0	
	Green(2)	0	0	0	0	0	0	0	0	0	0	0	0	0	1	0	0	0	0	0	0	0	0	0	
	⋮	⋮	⋮	⋮	⋮	⋮	⋮	⋮	⋮	⋮	⋮	⋮	⋮	⋮	⋮	⋮	⋮	⋮	⋮	⋮	⋮	⋮	⋮		
	⋮	⋮	⋮	⋮	⋮	⋮	⋮	⋮	⋮	⋮	⋮	⋮	⋮	⋮	⋮	⋮	⋮	⋮	⋮	⋮	⋮	⋮	⋮		
	⋮	⋮	⋮	⋮	⋮	⋮	⋮	⋮	⋮	⋮	⋮	⋮	⋮	⋮	⋮	⋮	⋮	⋮	⋮	⋮	⋮	⋮	⋮		
	Green(252)	0	0	0	0	0	0	0	0	1	1	1	1	1	1	0	1	0	0	0	0	0	0	0	
	Green(252)	0	0	0	0	0	0	0	0	1	1	1	1	1	1	1	0	0	0	0	0	0	0	0	
Green(252)	0	0	0	0	0	0	0	1	1	1	1	1	1	1	1	0	0	0	0	0	0	0	0		
Gray Scale Of Blue	Blue(0) / Dark	0	0	0	0	0	0	0	0	0	0	0	0	0	0	0	0	0	0	0	0	0	0	0	
	Blue(1)	0	0	0	0	0	0	0	0	0	0	0	0	0	0	0	0	0	0	0	0	0	0	1	
	Blue(2)	0	0	0	0	0	0	0	0	0	0	0	0	0	0	0	0	0	0	0	0	0	0	1	
	⋮	⋮	⋮	⋮	⋮	⋮	⋮	⋮	⋮	⋮	⋮	⋮	⋮	⋮	⋮	⋮	⋮	⋮	⋮	⋮	⋮	⋮	⋮		
	⋮	⋮	⋮	⋮	⋮	⋮	⋮	⋮	⋮	⋮	⋮	⋮	⋮	⋮	⋮	⋮	⋮	⋮	⋮	⋮	⋮	⋮	⋮		
	⋮	⋮	⋮	⋮	⋮	⋮	⋮	⋮	⋮	⋮	⋮	⋮	⋮	⋮	⋮	⋮	⋮	⋮	⋮	⋮	⋮	⋮	⋮		
	Blue(252)	0	0	0	0	0	0	0	0	0	0	0	0	0	0	0	1	1	1	1	1	1	1	0	
	Blue(252)	0	0	0	0	0	0	0	0	0	0	0	0	0	0	0	1	1	1	1	1	1	1	0	
Blue(252)	0	0	0	0	0	0	0	0	0	0	0	0	0	0	0	1	1	1	1	1	1	1	1		

Note (1) 0: Low Level Voltage, 1: High Level Voltage

6. INTERFACE TIMING

6.1 INPUT SIGNAL TIMING SPECIFICATIONS

The input signal timing specifications are shown as the following table and timing diagram.

Signal	Item	Symbol	Min.	Typ.	Max.	Unit	Note
DCLK	Pixel Clock	$1/T_C$	60.40	71.1	74.7	MHz	-
DE	Vertical Total Time	T_V	810	823	829	T_H	-
	Vertical Address Time	T_{VD}	800	800	800	T_H	-
	Horizontal Total Time	T_H	1362	1440	1480	T_C	-
	Horizontal Address Time	T_{HD}	1280	1280	1280	T_C	-

Note (1) Because this module is operated by DE only mode, Hsync and Vsync input signals should be set to low logic level or ground. Otherwise, this module would operate abnormally.

INPUT SIGNAL TIMING DIAGRAM

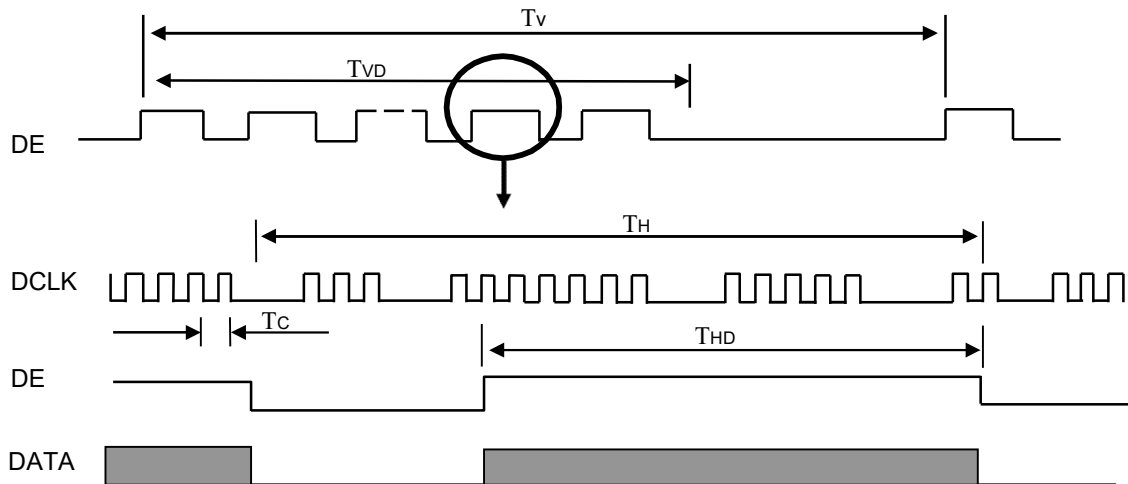

TIMING DIAGRAM of LVDS

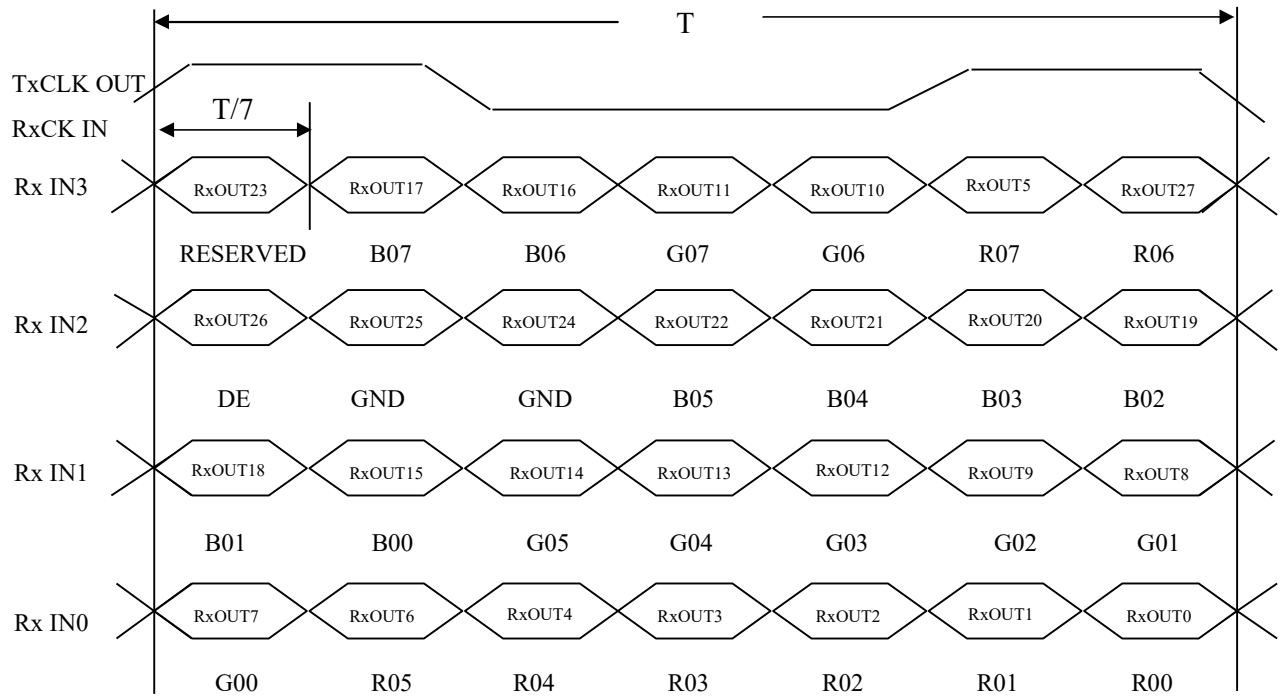

6.2 POWER ON/OFF SEQUENCE

To prevent a latch-up or DC operation of LCD assembly, the power on/off sequence should be as the diagram below.

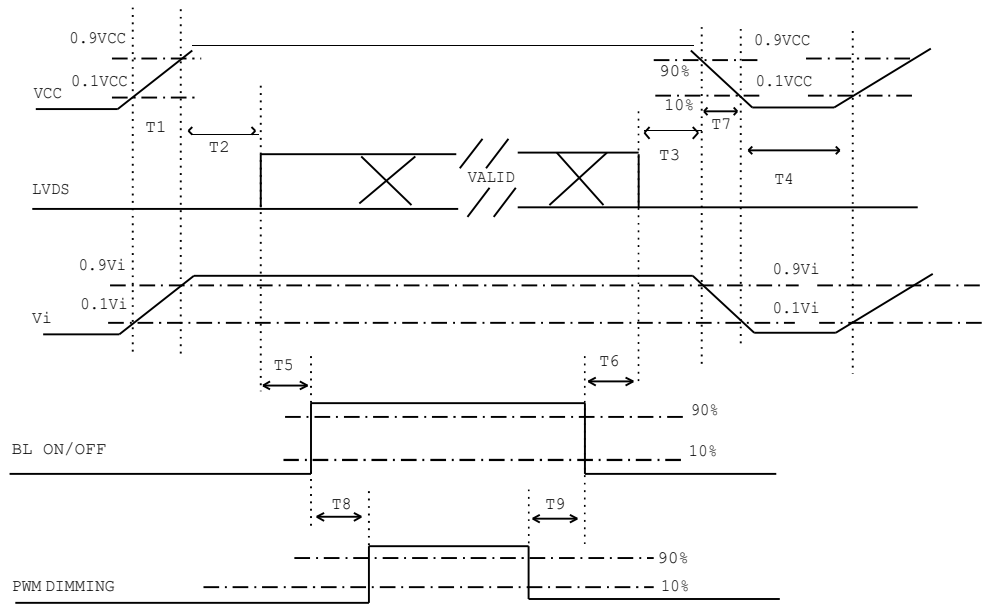

Power ON/OFF sequence

Note (1) Please avoid floating state of interface signal at invalid period.

Note (2) When the interface signal is invalid, be sure to pull down the power supply of LCD VCC to 0 V.

Note (3) The Backlight converter power must be turned on after the power supply for the logic and the interface signal is valid. The Backlight converter power must be turned off before the power supply for the logic and the interface signal is invalid.

Parameter	Value			Units
	Min	Typ	Max	
T1	0.5	-	10	ms
T2	0	-	50	ms
T3	0	-	50	ms
T4	500	-	-	ms
T5	200	-	-	ms
T6	200	-	-	ms
T7	5	-	300	ms
T8	10	-	-	ms
T9	10	-	-	ms

7. OPTICAL CHARACTERISTICS

7.1 TEST CONDITIONS

Item	Symbol	Value	Unit
Ambient Temperature	Ta	25±2	°C
Ambient Humidity	Ha	50±10	%RH
Supply Voltage	V _{CC}	3.3	V
Input Signal	According to typical value in "3. ELECTRICAL CHARACTERISTICS"		
Converter Voltage	V _i	12	V
Converter Duty		100%	

OPTICAL SPECIFICATIONS

The relative measurement methods of optical characteristics are shown in 7.2. The following items should be measured under the test conditions described in 7.1 and stable environment shown in Note (5).

Item	Symbol	Condition	Min.	Typ.	Max.	Unit	Note		
Color Chromaticity	Red	$\theta_x=0^\circ, \theta_y=0^\circ$	Typ - 0.05	Typ+ 0.05	-	-	(1), (5)		
								R _x	0.592
	R _y							0.340	
	Green							G _x	0.316
								G _y	0.591
	Blue							B _x	0.154
								B _y	0.123
	White							W _x	0.313
W _y		0.329							
Center Luminance of White	L _c		300	400		cd/m ²	(4), (5)		
Contrast Ratio	CR		600	800		-	(2), (5)		
Response Time	T _R	$\theta_x=0^\circ, \theta_y=0^\circ$	-	14	17	ms	(3)		
	T _F							11	
White Variation	δW	$\theta_x=0^\circ, \theta_y=0^\circ$	70	-	-	%	(5), (6)		
Viewing Angle	Horizontal	CR ≥ 10	80	85	-	Deg.	(1), (5)		
								θ _{x+}	
	θ _{x-}								
	Vertical							θ _{y+}	80
θ _{y-}		80	85	-					

Note (1) Definition of Viewing Angle (θ_x, θ_y):

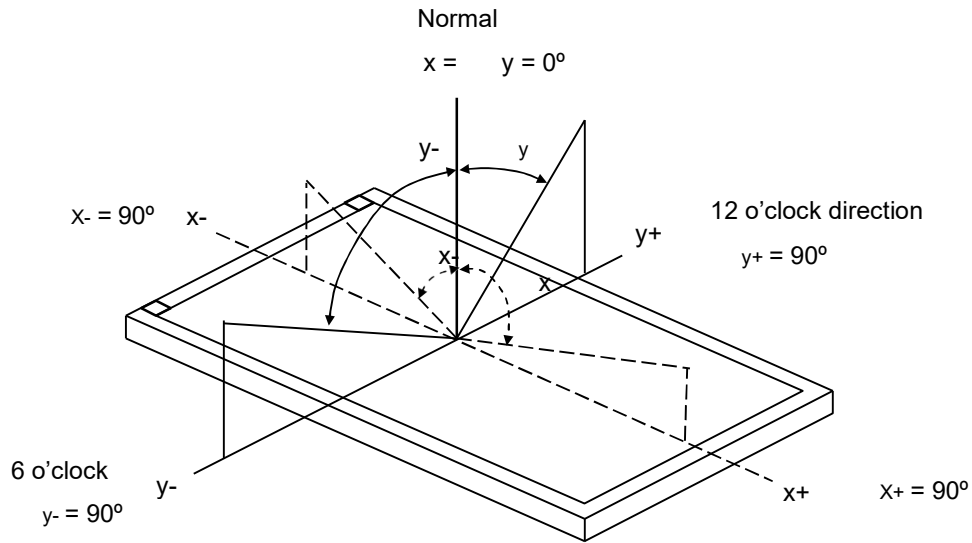

Note (2) Definition of Contrast Ratio (CR):

The contrast ratio can be calculated by the following expression.

$$\text{Contrast Ratio (CR)} = L_{252} / L_0$$

L252: Luminance of gray level 252

L0: Luminance of gray level 0

$$CR = CR(5)$$

CR (X) is corresponding to the Contrast Ratio of the point X at Figure in Note (6).

Note (3) Definition of Response Time (T_R, T_F):

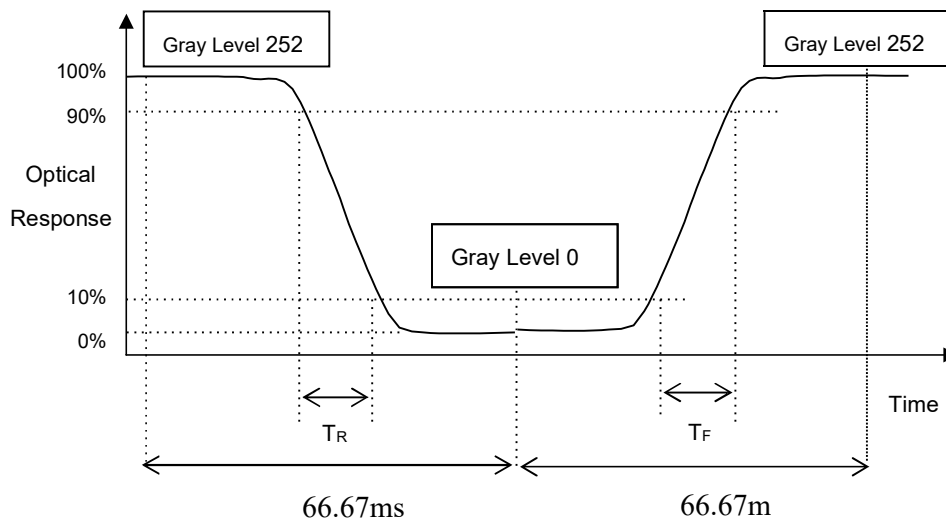

Note (4) Definition of Luminance of White (L_c):

Measure the luminance of gray level 252 at center point

$$L_c = L(5)$$

$L(x)$ is corresponding to the luminance of the point X at Figure in Note (6).

Note (5) Measurement Setup:

The LCD module should be stabilized at given temperature for 20 minutes to avoid abrupt temperature change during measuring. In order to stabilize the luminance, the measurement should be executed after lighting Backlight for 20 minutes in a windless room.

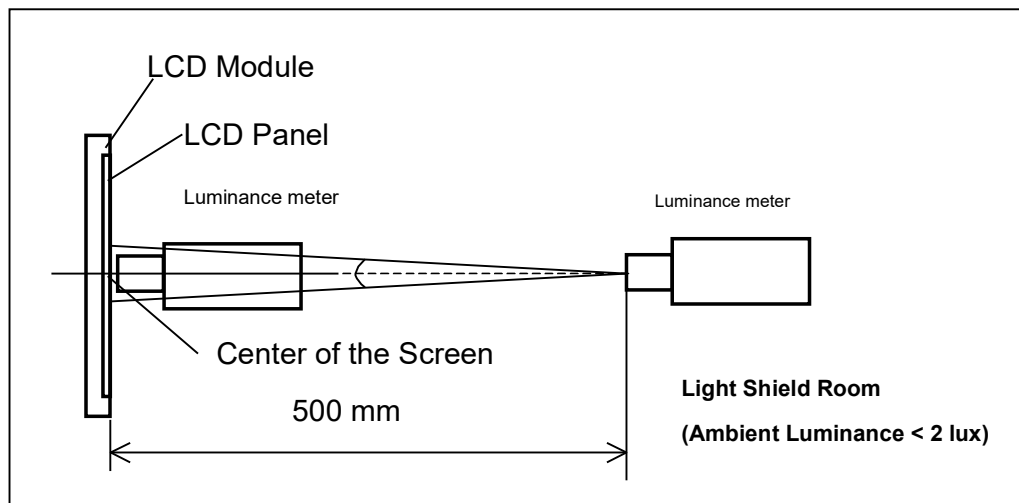

Note (6) Definition of White Variation (δW):

Measure the luminance of gray level 252 at 5 points

$$W_{5p} = \{ \text{Minimum} [L(1) \sim L(5)] / \text{Maximum} [L(1) \sim L(5)] \} * 100\%$$

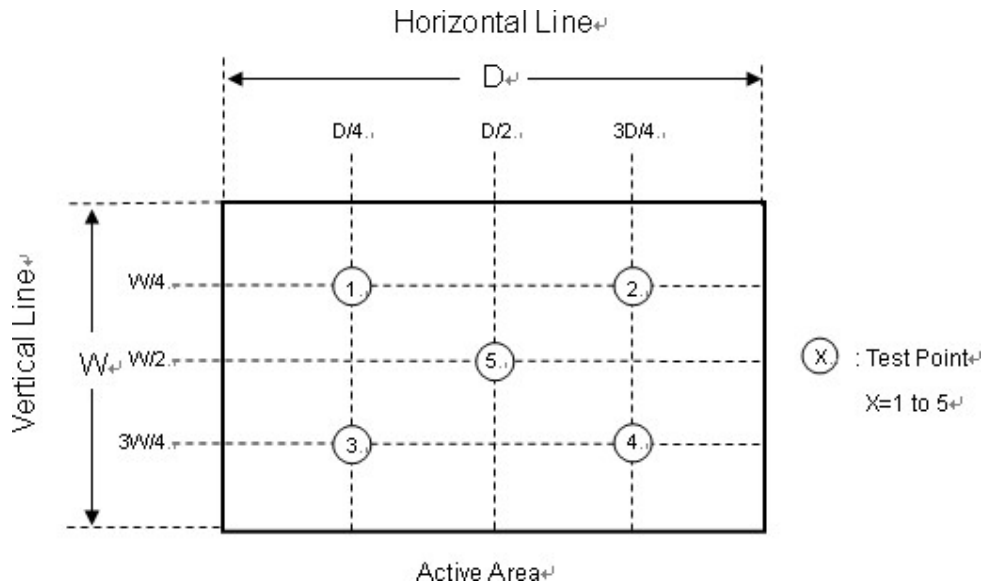

8. TOUCH SCREEN SPECIFICATION

General Specifications	
Type	Analog Resistive type
Size	As per drawing
Input Method	Stylus or Finger
Glass Thickness	1.1 mm
Environmental Specifications	
Operating Temperature	-30° to +70° C
Storage Temperature	-40° to +80° C
Operating Humidity	20% to 85% RH (Non Condensing)
Storage Humidity	10% to 90% RH (Non Condensing)
Optical Specifications	
Transparency	≥ 85% (± 3%)
Haze	< 3%
Electrical Specifications	
Max. Voltage	5V DC
Max. Current	35mA
Loop Resistance	X: 20~500Ω, Y: 20~500Ω
Linearity	X ≤ 1.5%, Y ≤ 1.5%
Chattering	≤ 15ms
Insulation	≥ 20MΩ/25V (DC)
Mechanical Specifications	
Operating Force	10-80 g
Durability	3,000,000 touch at a single point
Hardness	> 3H
Capacitance	< 5 nF

9. RELIABILITY TEST CRITERIA

Test Item	Test Condition	Note
High Temperature Storage Test	70°C, 240 hours	(1), (2) (4)
Low Temperature Storage Test	-25°C, 240 hours	
Thermal Shock Storage Test	-25°C, 0.5 hour ↔ 70°C, 0.5 hour; 100cycles, 1 hour/cycle)	
High Temperature Operation Test	65°C, 240 hours	
Low Temperature Operation Test	-20°C, 240 hours	
High Temperature & High Humidity Operation Test	60°C, RH 90%, 240 hours	
ESD Test (Operation)	150pF, 330Ω, 1 sec/cycle Condition 1 : panel contact, ±8 KV Condition 2 : panel non-contact ±15 KV	(1)
Shock (Non-Operating)	50G, 11ms, half sine wave, 1 time for ± X, ± Y, ± Z direction	(1), (3)
Vibration (Non-Operating)	1.5G, 10 ~ 300 Hz sine wave, 10 min/cycle, 3 cycles each X, Y, Z direction	(1), (3)

Note (1) No display malfunction.

Note (2) Judgment should be tested after storage at room temperature for more than two hour. All the cosmetic specification is judged before reliability test.

Note (3) At testing Vibration and Shock, the fixture in holding the module has to be hard and rigid enough so that the module would not be twisted or bent by the fixture.

Note (4) Temperature of panel display surface area should be 75°C Max.

10. MODULE LABEL



11. PRECAUTIONS

ASSEMBLY AND HANDLING PRECAUTIONS

- (1) Do not apply rough force such as bending or twisting to the module during assembly.
- (2) To assemble or install module into user's system can be only in clean working areas. The dust and oil may cause electrical short or worsen the polarizer.
- (3) It's not permitted to have pressure or impulse on the module because the LCD panel and Backlight will be damaged.
- (4) Always follow the correct power sequence when LCD module is connecting and operating. This can prevent damage to the CMOS LSI chips during latch-up.
- (5) Do not pull the I/F connector in or out while the module is operating.
- (6) Do not disassemble the module.
- (7) Use a soft dry cloth without chemicals for cleaning, because the surface of polarizer is very soft and easily scratched.
- (8) It is dangerous that moisture come into or contacted the LCD module, because moisture may damage LCD module when it is operating.
- (9) High temperature or humidity may reduce the performance of module. Please store LCD module within the specified storage conditions.
- (10) When ambient temperature is lower than 10°C may reduce the display quality. For example, the response time will become slowly.
- (11) Do not keep same pattern in a long period of time. It may cause image sticking on LCD.

SAFETY PRECAUTIONS

- (1) Do not disassemble the module or insert anything into the Backlight unit.
- (2) If the liquid crystal material leaks from the panel, it should be kept away from the eyes or mouth. In case of contact with hands, skin or clothes, it has to be washed away thoroughly with soap.
- (3) After the module's end of life, it is not harmful in case of normal operation and storage.

12. MECHANICAL CHARACTERISTICS
(To be advised)