



HIGHNESSTM

One of a kind

HM070WV311I-RT

7" Color TFT-LCD

With Resistive Touch Screen

Release Date
12th Mar 2021

THIS DOCUMENT CONTAINS PROPRIETARY INFORMATION WHICH IS SOLELY OWENED BY 'HIGHNESS MICROELECTRONICS LTD.'" ANY UNAUTHORISED COPY OR PRINTING OR PUBLISHING OF INFORMATION IN THIS DOCUMENT IN PART OR IN COMPLETE IS RESTRICTED.

HIGHNESS MICROELECTRONICS LTD.

URL: www.highnessmicro.com, Email: sales@highnessmicro.com

1. General Specifications

No.	Item	Specification
1	LCD size	7.0 inch (Diagonal)
2	Driver element	a-Si TFT active matrix
3	Resolution	800 × 3(RGB) × 480
4	Display mode	Normally White, Transmissive
5	Dot pitch	0.0642(W) × 0.1790(H) mm
6	Active area	154.08(W) × 85.92(H) mm
7	Module size	164.9(W) × 100.0(H) mm
8	Bezel opening size	157.08(W) × 88.92(H) mm
9	Touch Screen Type	Resistive Touch
10	Touch Screen Interface	USB
11	Surface treatment	Anti-Glare
12	Color arrangement	RGB-stripe
13	Interface	Digital
14	Backlight power consumption	3.385 W(Typ.)
15	Panel power consumption	0.226W (Typ.)
16	Weight	150g (Max.)

2. Pin Assignment

FPC Connector is used for the module electronics interface. The recommended model is FH12A-50S-0.5SH manufactured by Hirose.

Pin No.	Symbol	I/O	Function	Remark
1	VLED+	P	Power for LED backlight (Anode)	
2	VLED+	P	Power for LED backlight (Anode)	
3	VLED-	P	Power for LED backlight (Cathode)	
4	VLED-	P	Power for LED backlight (Cathode)	
5	GND	P	Power ground	
6	VCOM	I	Common voltage	
7	DV _{DD}	P	Power for Digital Circuit	
8	MODE	I	DE/SYNC mode select	Note 1
9	DE	I	Data Input Enable	
10	VS	I	Vertical Sync Input	
11	HS	I	Horizontal Sync Input	
12	B7	I	Blue data(MSB)	
13	B6	I	Blue data	
14	B5	I	Blue data	
15	B4	I	Blue data	
16	B3	I	Blue data	
17	B2	I	Blue data	
18	B1	I	Blue data	Note 2
19	B0	I	Blue data(LSB)	Note 2
20	G7	I	Green data(MSB)	
21	G6	I	Green data	
22	G5	I	Green data	
23	G4	I	Green data	
24	G3	I	Green data	
25	G2	I	Green data	

26	G1	I	Green data	Note 2
27	G0	I	Green data(LSB)	Note 2
28	R7	I	Red data(MSB)	
29	R6	I	Red data	
30	R5	I	Red data	
31	R4	I	Red data	
32	R3	I	Red data	
33	R2	I	Red data	
34	R1	I	Red data	Note 2
35	R0	I	Red data(LSB)	Note 2
36	GND	P	Power Ground	
37	DCLK	I	Sample clock	Note 3
38	GND	P	Power Ground	
39	L/R	I	Left / right selection	Note 4,5
40	U/D	I	Up/down selection	Note 4,5
41	VGH	P	Gate ON Voltage	
42	VGL	P	Gate OFF Voltage	
43	AV _{DD}	P	Power for Analog Circuit	
44	RESET	I	Global reset pin.	Note 6
45	NC	-	No connection	
46	VCOM	I	Common Voltage	
47	DITHB	I	Dithering function	Note 7
48	GND	P	Power Ground	
49	NC	-	No connection	
50	NC	-	No connection	

I: input, O: output, P: Power

Note 1: DE/SYNC mode select. Normally pull high.

When select DE mode, MODE="1", VS and HS must pull high.

When select SYNC mode, MODE="0", DE must be grounded.

Note 2: When input 18 bits RGB data, the two low bits of R,G and B data must be grounded.

Note 3: Data shall be latched at the falling edge of DCLK.

Note 4: Selection of scanning mode

Setting of scan control input		Scanning direction
U/D	L/R	
GND	DV _{DD}	Up to down, left to right
DV _{DD}	GND	Down to up, right to left
GND	GND	Up to down, right to left
DV _{DD}	DV _{DD}	Down to up, left to right

Note 5: Definition of scanning direction.

Refer to the figure as below:

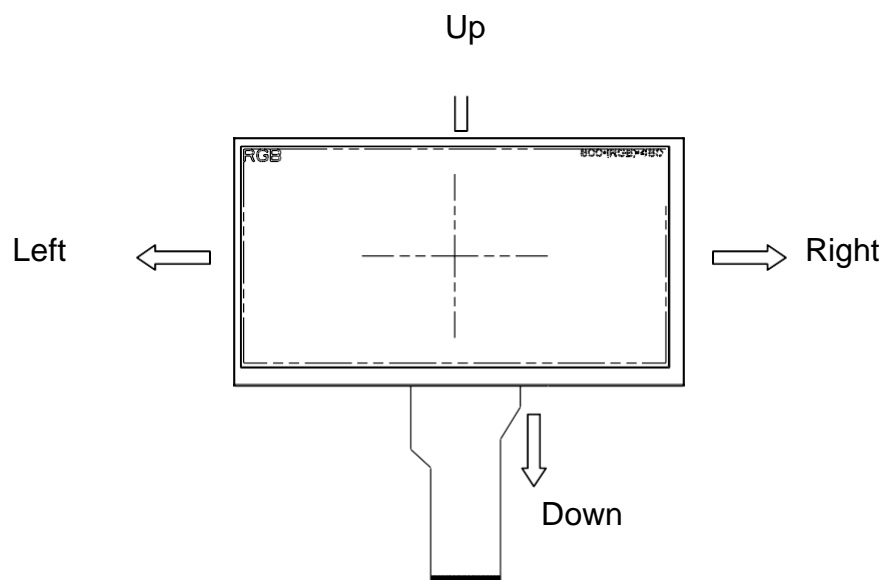

Note 6: Global reset pin. Active low to enter reset state. Suggest to connect with an RC reset circuit for stability. Normally pull high.

Note 7: Dithering function enable control, normally pull high.
 When DITHB="1", Disable internal dithering function,
 When DITHB="0", Enable internal dithering function,

3. Operation Specifications

3.1. Absolute Maximum Ratings

Item	Symbol	Values		Unit	Remark
		Min.	Max.		
Power voltage	DV _{DD}	-0.3	5.0	V	
	AV _{DD}	6.5	13.5	V	
	V _{GH}	-0.3	40.0	V	
	V _{GL}	- 20.0	0.3	V	
	V _{GH} - V _{GL}	-	40.0	V	
Operation Temperature	T _{OP}	-30	85	°C	
Storage Temperature	T _{ST}	-40	90	°C	
LED Reverse Voltage	V _R	-	5	V	Each LED Note 2
LED Forward Current	I _F	-	70	mA	Each LED

Note 1: The absolute maximum rating values of this product are not allowed to be exceeded at any times. Should a module be used with any of the absolute maximum ratings exceeded, the characteristics of the module may not be recovered, or in an extreme case, the module may be permanently destroyed.

Note 2 : V_R conditions : Zener Diode 20mA

3.1.1. Typical Operation Conditions

Item	Symbol	Values			Unit	Remark
		Min.	Typ.	Max.		
Power voltage	DV _{DD}	3.0	3.3	3.6	V	Note 2
	AV _{DD}	10.2	10.4	10.6	V	
	V _{G H}	15.3	16.0	16.7	V	
	V _{G L}	-7.7	-7.0	-6.3	V	
Input signal voltage	V _{COM}	2.6	(3.6)	4.6	V	Note 4
Input logic high voltage	V _{IH}	0.7 DV _{DD}	-	DV _{DD}	V	Note 3
Input logic low voltage	V _{IL}	0	-	0.3 DV _{DD}	V	

Note 1: Be sure to apply DV_{DD} and V_{GL} to the LCD first, and then apply V_{GH}.

Note 2: DV_{DD} setting should match the signals output voltage (refer to Note 3) of customer's system board. Note 3: DCLK,HS,VS,RESET,U/D, L/R,DE,R0~R7,G0~G7,B0~B7,MODE,DITHB.

Note 4: Typical V_{COM} is only a reference value. It must be optimized according to each LCM. Please use VRand base on below application circuit.

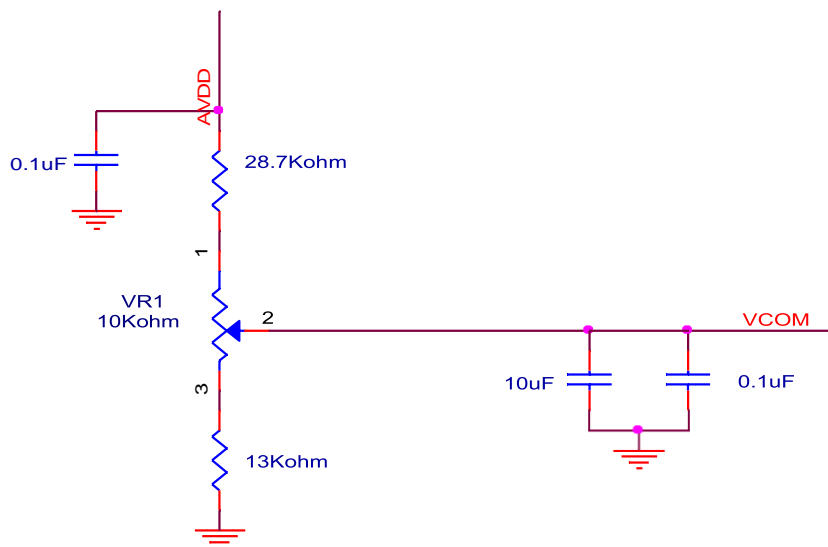

3.1.2. Current Consumption

Item	Symbol	Values			Unit	Remark
		Min.	Typ.	Max		
Current for Driver	I _{GH}	-	0.2	1.0	mA	V _{GH} =16.0V
	I _{GL}	-	0.2	1.0	mA	V _{GL} = -7.0V
	IDV _{DD}	-	4.0	10	mA	DV _{DD} =3.3V
	I _{AV} _{DD}	-	20	50	mA	AV _{DD} =10.4V

3.1.3. Backlight Driving Conditions

Item	Symbol	Values			Unit	Remark
		Min.	Typ.	Max.		
Voltage for LED backlight	V _L	19.6	21.7	23.8	V	Note 1
Current for LED backlight	I _L	-	156	-	mA	
LED life time	-	20,000	-	-	Hr	Note 2

Note 1: The LED Supply Voltage is defined by the number of LED at Ta=25°C and I_L =180mA

Note 2: The “LED life time” is defined as the module brightness decrease to 50% original brightness at Ta=25°C and I_L = 180mA. The LED lifetime could be decreased if operating I_L is larger than 180mA.

3.2. Power Sequence

a. Power on:

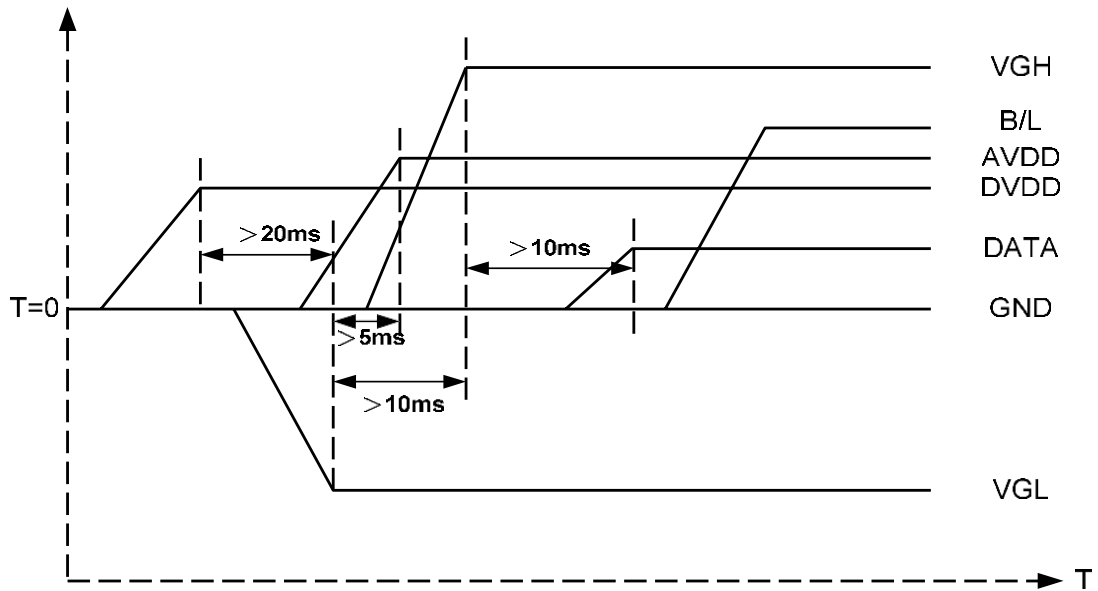

DV_{DD}→RSTB→VGL→AVDD→VGH→Data→B/L

b. Power off:

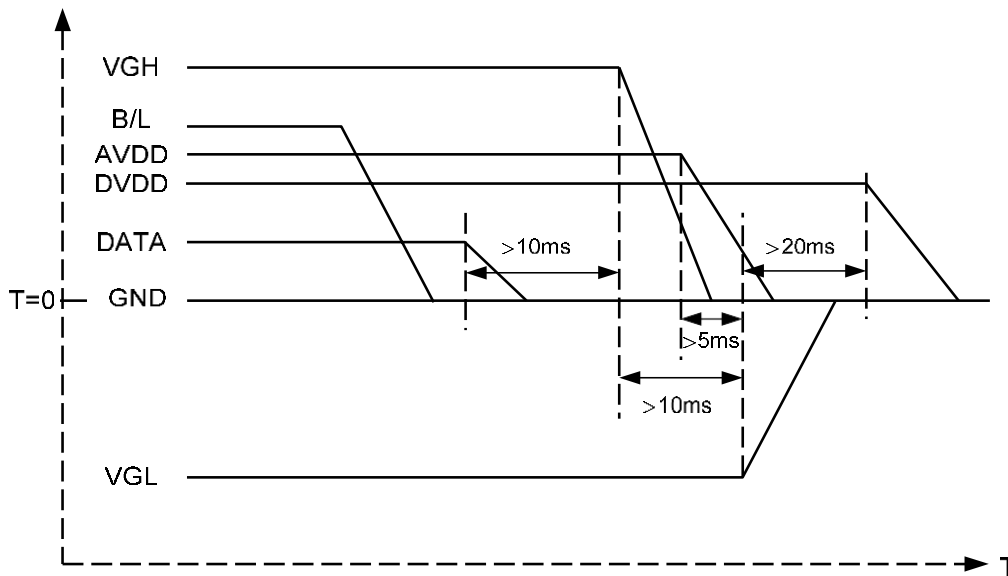

B/L→Data→VGH→AVDD→VGL→RSTB→DV_{DD}

Note: Data include R0~R7, B0~B7, GO~G7, U/D, L/R, DCLK, HS,VS,DE.

3.3. Timing Characteristics

3.3.1. AC Electrical Characteristics

Item	Symbol	Values			Unit	Remark
		Min	Typ.	Max		
HS setup time	Thst	8	-	-	ns	
HS hold time	Thhd	8	-	-	ns	
VS setup time	Tvst	8	-	-	ns	
VS hold time	Tvhd	8	-	-	ns	
Data setup time	Tdsu	8	-	-	ns	
Data hole time	Tdhd	8	-	-	ns	
DE setup time	Tesu	8	-	-	ns	
DE hole time	Tehd	8	-	-	ns	
DV _{DD} Power On Slew rate	TPOR	-	-	20	ms	From 0 to 90% DV _{DD}
RESET pulse width	TRst	1	-	-	ms	
DCLK cycle time	Tcoh	20	-	-	ns	
DCLK pulse duty	Tcwh	40	50	60	%	

3.3.2. Input Clock and Data Timing Diagram

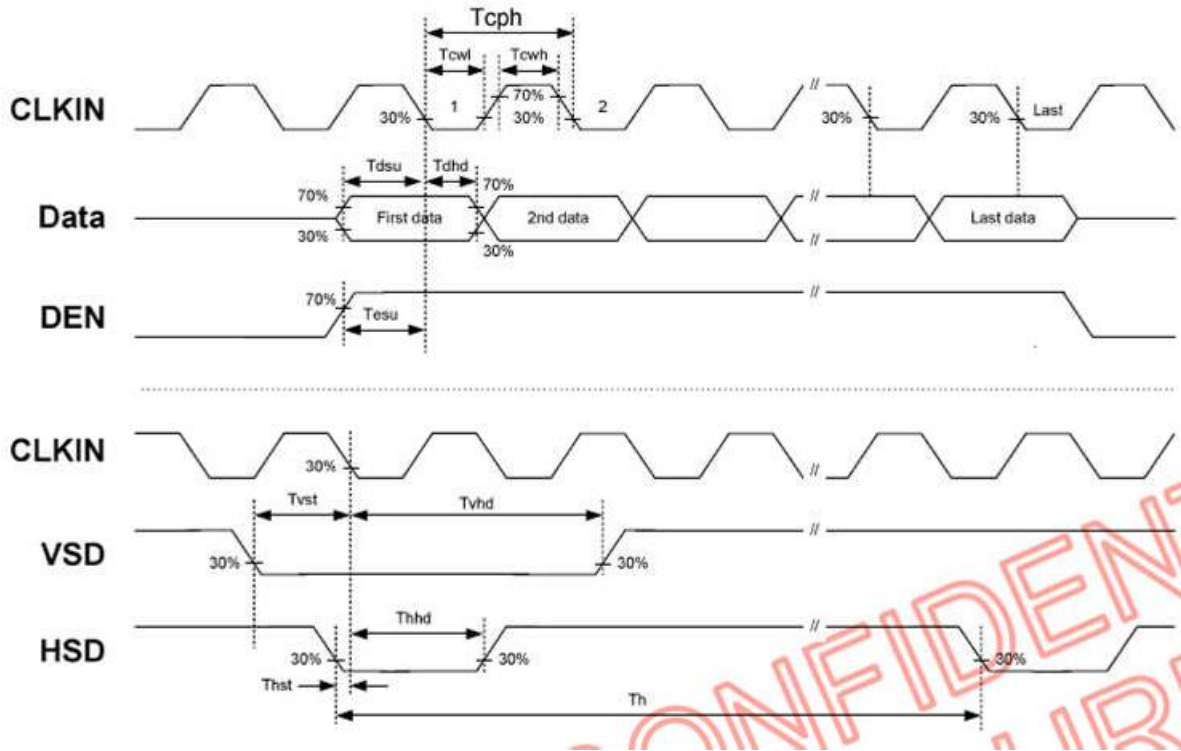

3.3.3. Timing

Item	Symbol	Values			Unit	Remark
		Min	Typ.	Max		
Horizontal Display Area	thd	-	800	-	DCLK	
DCLK Frequency	fclk	26.4	33.3	46.8	MHz	
One Horizontal Line	th	862	1056	1200	DCLK	
HS pulse width	thp w	1	-	40	DCLK	
HS Blanking	thb	46	46	46	DCLK	
HS Front Porch	thfp	16	210	354	DCLK	

Item	Symbol	Values			Unit	Remark
		Min.	Typ.	Max		
Vertical Display Area	tvd	-	480	-	TH	
VS period time	tv	510	525	650	TH	
VS pulse width	tvpw	1	-	20	TH	
VS Blanking	tvb	23	23	23	TH	
VS Front Porch	tvfp	7	22	147	TH	

3.3.4. Data Input Format

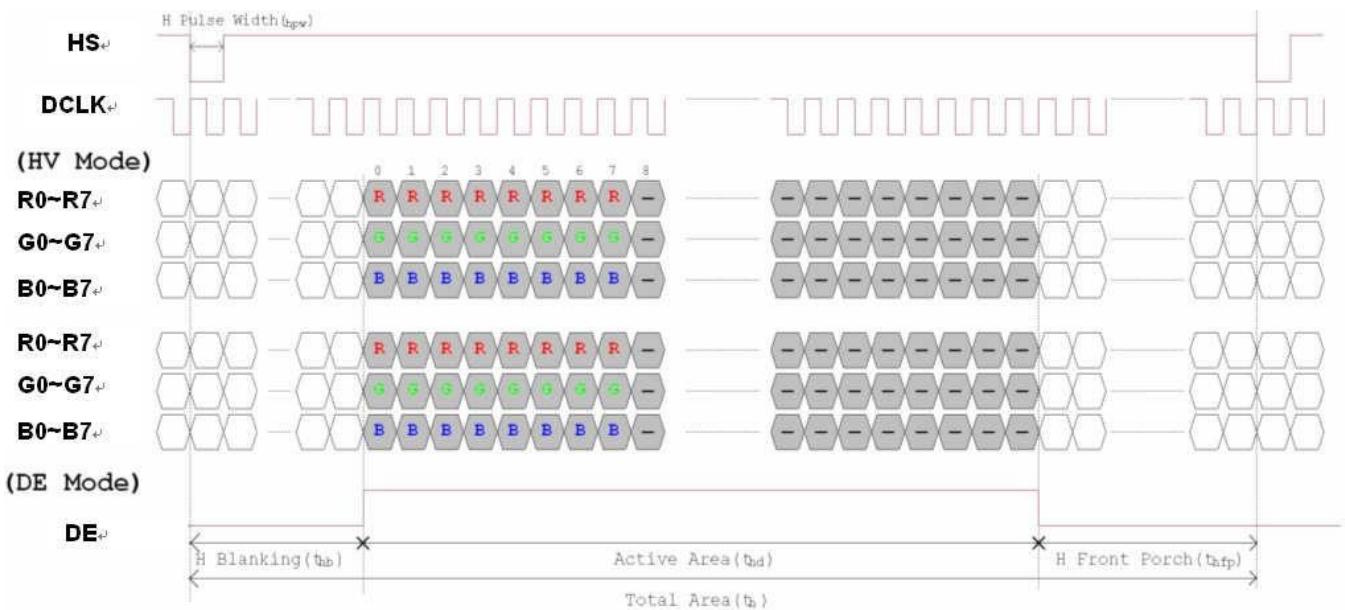

Figure 3. 1 Horizontal input timing diagram.

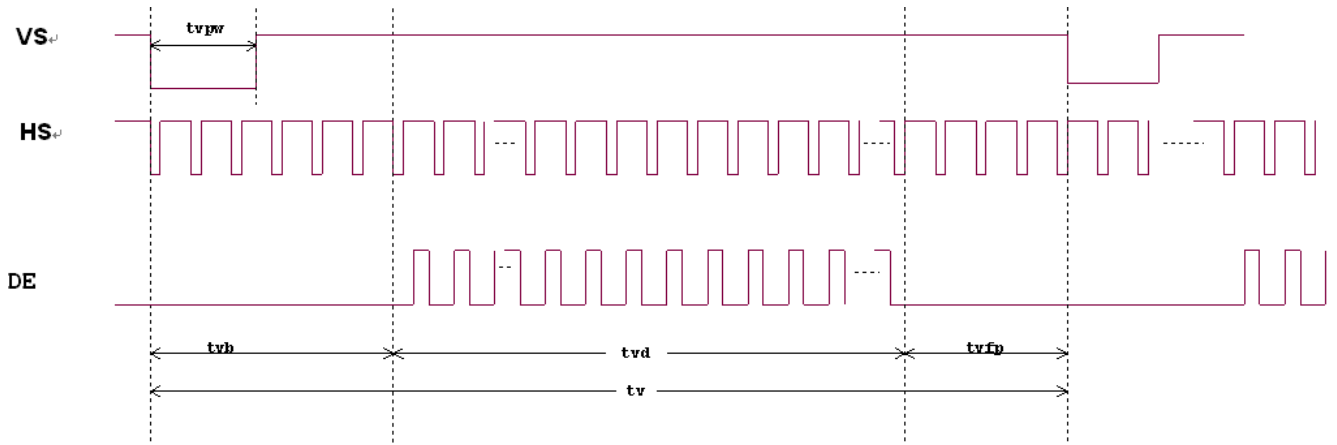

Figure 3. 2 Vertical input timing diagram.

4. Optical Specifications

Item	Symbol	Condition	Values			Unit	Remark
			Min.	Typ.	Max.		
Viewing angle(CR≥10)	θ_L	$\Phi=180^\circ(9 \text{ o'clock})$	60	70	-	degree	Note 1
	θ_R	$\Phi=0^\circ(3 \text{ o'clock})$	60	70	-		
	θ_T	$\Phi=90^\circ(12 \text{ o'clock})$	40	50	-		
	θ_B	$\Phi=270^\circ(6 \text{ o'clock})$	60	70	-		
Response time	$T_r + T_f$	Normal $\theta=\Phi=0^\circ$	-	20	-	msec	Note 3
Contrast ratio	CR		300	400	-	-	Note 4
Color chromaticity	W_x		0.27	0.31	0.35	-	Note 2 Note 5 Note 6
	W_y		0.29	0.33	0.37	-	
Luminance	L		600	-	-	cd/m ²	Note 6
Luminance uniformity	Y_U		70	75	-	%	Note 7

Test Conditions:

1. $DV_{DD}=3.3V$, $I_L=156mA$ (Backlight current), the ambient temperature is 25°C.

2. The test systems refer to Note 2.

Note 1: Definition of viewing angle range

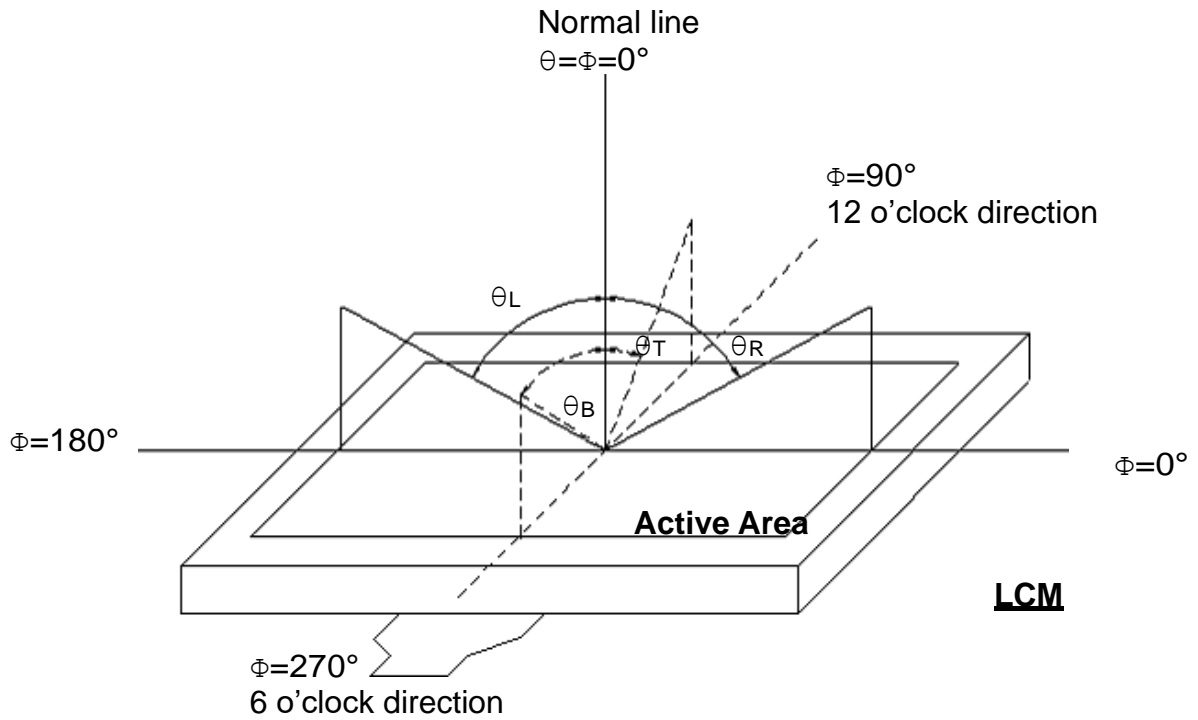

Fig. 4-1 Definition of viewing angle

Note 2: Definition of optical measurement system.

The optical characteristics should be measured in dark room. After 30 minutes operation, the optical properties are measured at the center point of the LCD screen. (Response time is measured by Photo detector TOPCONBM-7, other items are measured by BM-5A/Field of view: 1° /Height: 500mm.)

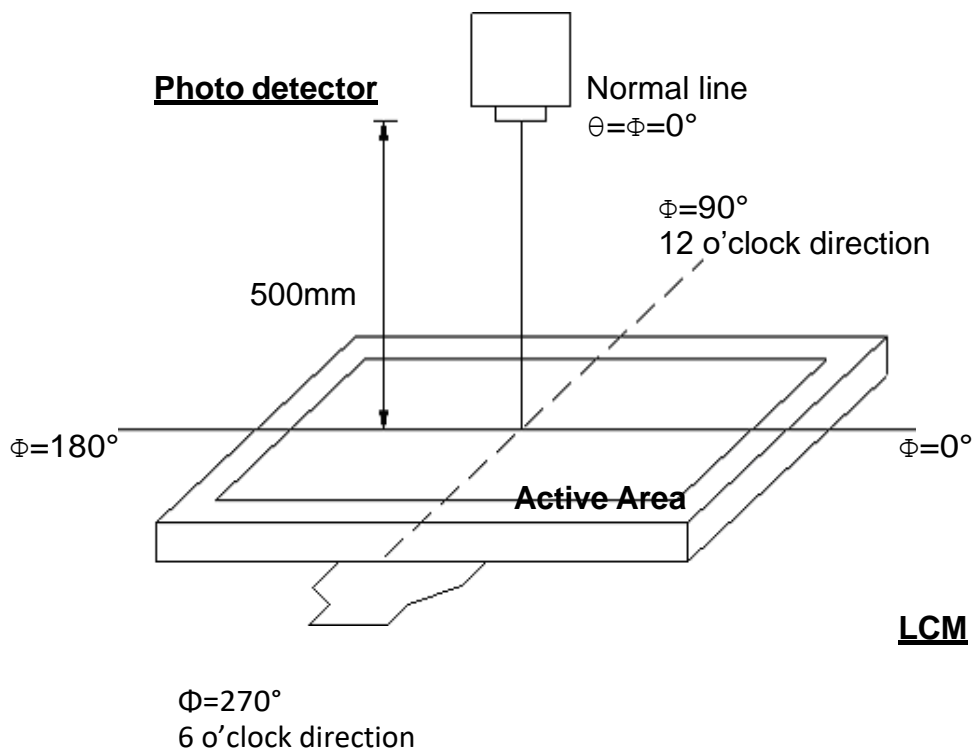

Fig. 4-2 Optical measurement system setup

Note 3: Definition of Response time

The response time is defined as the LCD optical switching time interval between "White" state and "Black" state. Rise time (T_{ON}) is the time between photo detector output intensity changed from 90% to 10%. And fall time (T_{OFF}) is the time between photo detector output intensity changed from 10% to 90%.

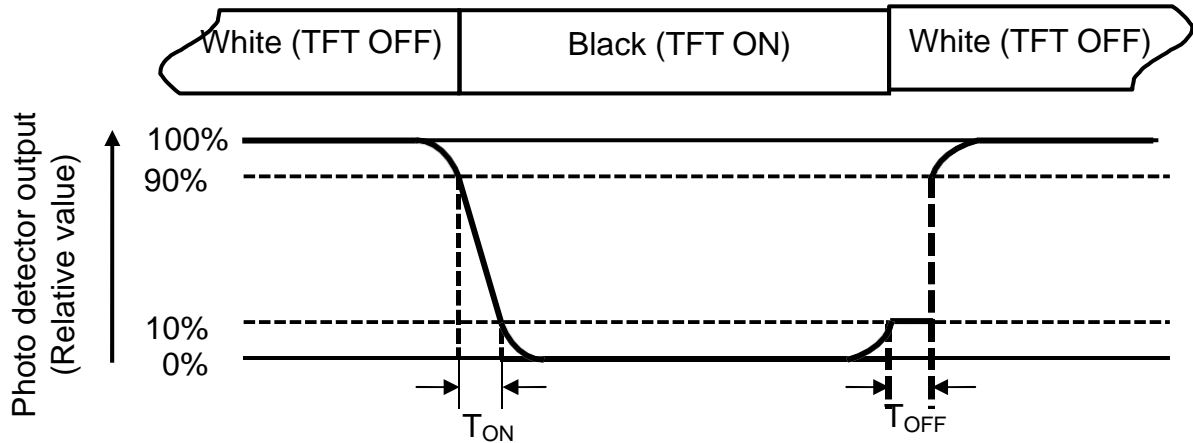

Fig. 4-3 Definition of response time

Note 4: Definition of contrast ratio

$$\text{Contrast ratio (CR)} = \frac{\text{Luminance measured when LCD on the "White" state}}{\text{Luminance measured when LCD on the "Black" state}}$$

Note 5: Definition of color chromaticity (CIE1931)

Color coordinates measured at center point of LCD.

Note 6: All input terminals LCD panel must be ground while measuring the center area of the panel. The LED driving condition is $I_L=192\text{mA}$

Note 7: Definition of Luminance Uniformity

Active area is divided into 9 measuring areas (Refer to Fig. 4-4).Every measuring point is placed at the center of each measuring area.

$$\text{Luminance Uniformity (Yu)} = \frac{B_{min}}{B_{max}}$$

L-----Active area length

W -----Active area width

5.Touch Screen Specification

General Specifications	
Type	Analog Resistive type
Size	7"
Input Method	Stylus or Finger
Glass Thickness	1.1 mm
Environmental Specifications	
Operating Temperature	-30° to +70° C
Storage Temperature	-40° to +80° C
Operating Humidity	20% to 85% RH (Non-Condensing)
Storage Humidity	10% to 90% RH (Non-Condensing)
Optical Specifications	
Transparency	≥ 85% (± 3%)
Haze	< 3%
Electrical Specifications	
Max. Voltage	5V DC
Max. Current	35mA
Loop Resistance	X: 20~500Ω, Y: 20~500Ω
Linearity	X ≤ 1.5%, Y ≤ 1.5%
Chattering	≤ 15ms
Insulation	≥ 20MΩ/25V (DC)
Mechanical Specifications	
Operating Force	10-80 g
Durability	3,000,000 touch at a single point
Hardness	> 3H
Capacitance	< 5 nF

(2) Touch Screen Pin Assignment

1	Y+
2	X-
3	Y-
4	X+

6. Reliability Test Items

Item	Test Conditions	Remark
High Temperature Storage Test	90°C, 240 hours	(1)(2)(4)
Low Temperature Storage Test	-40°C, 240 hours	
High Temperature Operation Test	85°C, 240 hours	
Low Temperature Operation Test	-30°C, 240 hours	
High Temperature & High Humidity Operation Test	60°C, RH 90%, 240hours	
Thermal Shock	(-30°C 30min) →(85°C 30min)]/cycle · (Ramp rate≥20°C /min) , 100cycles	
ESD Test (Non-Operation)	Condition 1 : C = 150pF, R = 330Ω Contact Discharge, ± 8KV Condition 2 : C = 150pF, R = 330Ω, Air Discharge, ± 15KV	(1)
Mechanical Shock	100G for half sine 2 ms, 6 sides, for directions of ±X, ±Y, ±Z	(1)(3)
Mechanical Vibration	Frequency: 10 ~55~10Hz; Sweep Mode: Log Sweep Sweep time: 1Oct/min; Acceleration: 1.5G; Test time:2 hr for eachdirection of X, Y, Z.	(1)(3)
Packaging Vibration Test	1.47Grms X, Y, Z three axes (30min /axis) 5Hz (0.015G ² /Hz) · 100Hz(0.015G ² /Hz) · 200Hz(0.0037G ² /Hz)]	
Packaging Drop Test	72cm(weight≤10kg), 60cm(weight > 10kg);1times for 6-faces, 3-edges and 1-corner	

Note (1) criteria : Normal display image with no obvious non-uniformity and no line defect.

Note (2) Evaluation should be tested after storage at room temperature for more than two hour

Note (3) At testing Vibration and Shock, the fixture in holding the module has to be hard and rigid enough so that the module would not be twisted or bent by the fixture.

Note (4) A certain level of Mura (non-uniformity) of dark / black image will happen several days after high temperature testing (H.T.T.). There is a slowly part recovery over a long time (several months). Such a long exposure time like in H.T.T. will normally not happen in a real application. Therefore thetest H.T.T. was introduced to simulate cycles with normal conditions in-between but with the same total exposure time what show a significant reduced Mura.The root cause is related to tension generated due to different amount of shrinking in the stack oflayers in the polariser sheet. The effect is more significant on larger displays like this size. An investigation into alternative polariser material showed that there is no better alternative currentlyavailable.